

### HIGH PERFORMANCE CURRENT MODE CONTROLLER

The KIA3842P/F is high performance fixed frequency current mode controller. This is specifically designed for Off-Line and DC to DC converter applications offering the designer a cost effective solution with minimal external components. This integrated circuit feature a trimmed oscillator for precise duty cycle control, a temperature compensated reference, high gain error amplifier, current sensing comparator, and a high current totempole output ideally suited for driving a power MOSFET. Also included are protective features consisting of input and reference undervoltage lockouts each with hysteresis, cycle-by-cycle current limiting, programmable output deadtime, and a latch for single pulse metering.

These devices are available in 8pin dual-in-line plastic packages as well as the 14pin plastic, surface mount (FLP-14).

The FLP-14 package has separate power and ground pins for the totempole output stage. The KIA3842P/F has UVLO thresholds of 16V(on) and 10V(off), ideally suited for off-line converters.

### FEATURES

- Trimmed Oscillator Discharge Current for Precise Duty Cycle Control.
- Current Mode Operation to 500kHz.
- Automatic Feed Forward Compensation.
- Latching PWM for Cycle-By-Cycle Current Limiting.
- Internally Trimmed Reference with Undervoltage Lockout.
- High Current TotemPole Output.
- Undervoltage Lockout with Hysteresis.
- Low Start-up and Operating Current.

### MAXIMUM RATING (Ta=25°C)

CHARACTERISTIC	SYMBOL	RATING	UNIT
Total Power Supply and Zener Current	(I <sub>CC</sub> +I <sub>Z</sub> )	30	mA
Output Current, Source or Sink (Note 1)	I <sub>O</sub>	1.0	A
Output Energy (Capacitive Load Per Cycle)	W	5.0	μJ
Current Sense and Voltage Feedback inputs	V <sub>IN</sub>	-0.3 to + 5.5	V
Error Amp Output Sink Current	I <sub>O</sub>	10	mA
Power Dissipation	KIA3842P	1.25	W
	KIA3842F	862	mW
Operating Temperature	T <sub>a</sub>	0 to + 70	°C
Storage Temperature	T <sub>stg</sub>	-65 to + 150	°C

NOTE : 1. Maximum package power dissipation limits must be observed.

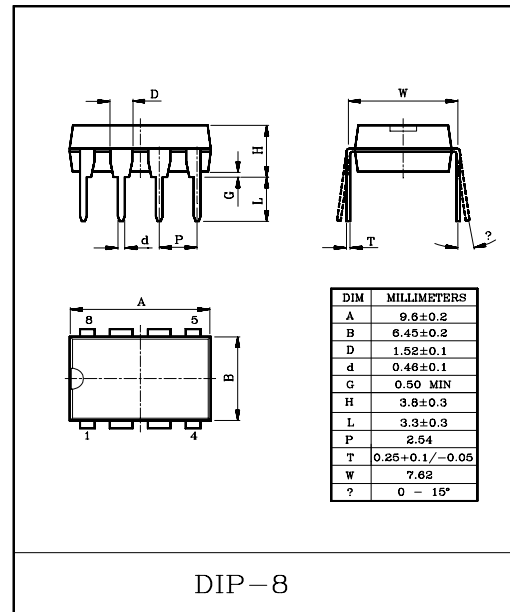

DIP-8

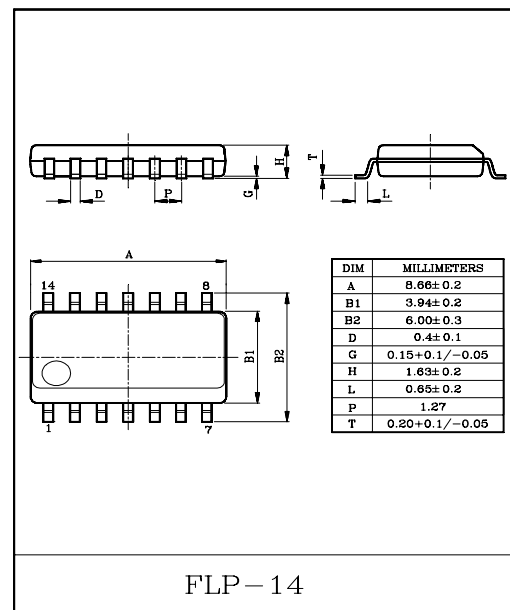

FLP-14

# KIA3842P/F

## PIN CONNECTIONS (TOP VIEW)

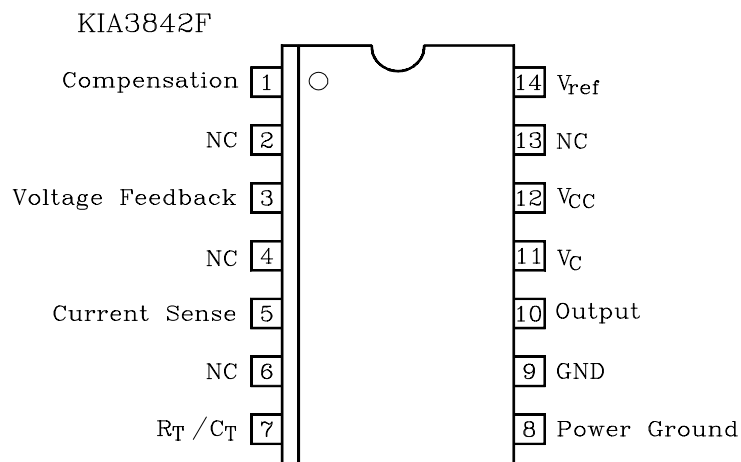
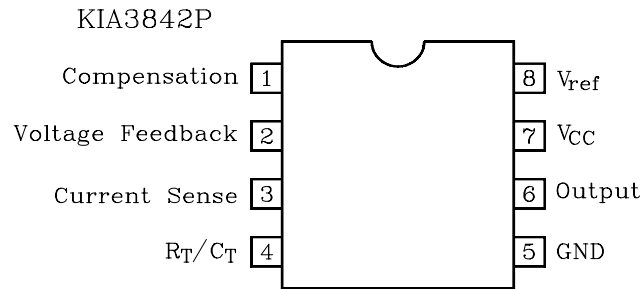

## BLOCK DIAGRAM

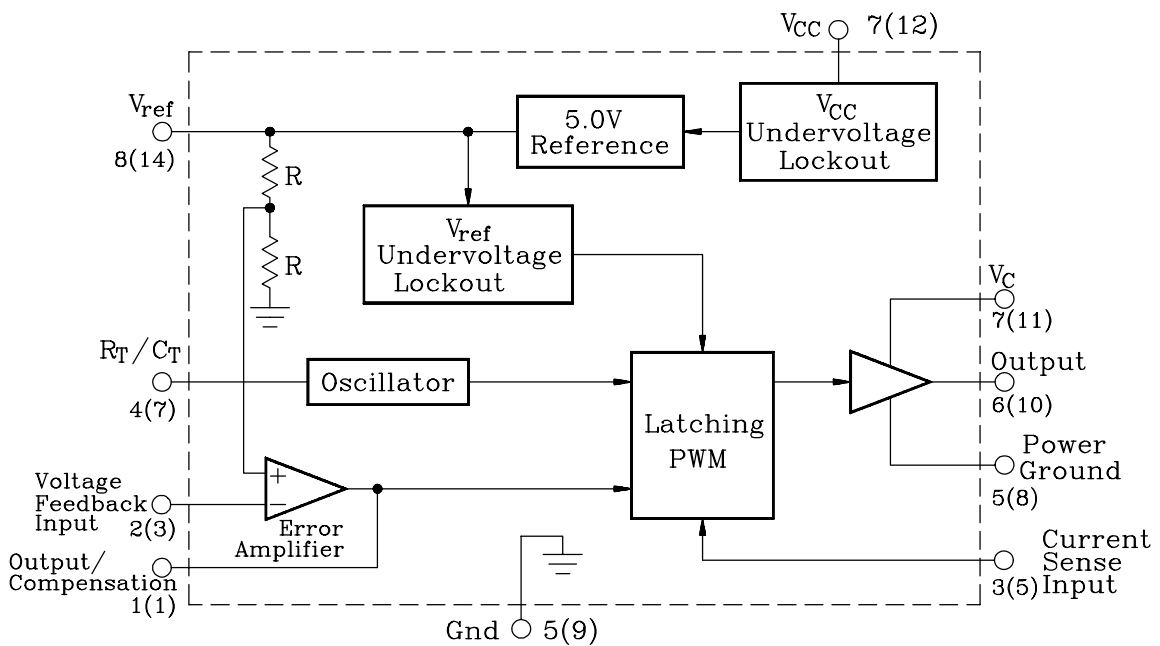

Pin numbers adjacent to terminals are for the DIP-8 package.  
Pin numbers in parenthesis are for the FLP-14 package.

# KIA3842P/F

ELECTRICAL CHARACTERISTICS (V<sub>CC</sub>=15V (Note 2), R<sub>T</sub>=10kΩ, C<sub>T</sub>=3.3nF, T<sub>a</sub>=25°C)

## REFERENCE SECTION

CHARACTERISTIC	SYMBOL	TEST CONDITION	MIN.	TYP.	MAX.	UNIT
Reference Output Voltage	V <sub>ref</sub>	I <sub>O</sub> =1.0mA, T <sub>a</sub> =25°C	4.9	5.0	5.1	V
Line Regulation	Reg <sub>line</sub>	V <sub>CC</sub> =12V~25V	-	2.0	20	mV
Load Regulation	Reg <sub>load</sub>	I <sub>O</sub> =1mA~20mA	-	3.0	25	mV
Temperature Stability	T <sub>S</sub>	-	-	0.2	-	mV/°C
Total Output Variation over Line, Load, and Temperature	V <sub>ref</sub>	-	4.82	-	5.18	V
Output Noise Voltage	V <sub>no</sub>	f=10Hz~10kHz, T <sub>a</sub> =25°C	-	50	-	μV
Long Term Stability	S	T <sub>a</sub> =125°C, 1000Hrs	-	5.0	-	mV
Output Short Circuit Current	I <sub>SC</sub>	-	-30	-85	-180	mA

## OSCILLATOR SECTION

CHARACTERISTIC	SYMBOL	TEST CONDITION	MIN.	TYP.	MAX.	UNIT
Frequency	f <sub>osc</sub>	T <sub>a</sub> =25°C	47	52	57	kHz
Frequency Change With Voltage	Δf <sub>osc</sub> /ΔV	V <sub>CC</sub> =12V~25V	-	0.2	1.0	%
Frequency Change With Temperature	Δf <sub>osc</sub> /ΔT	T <sub>a</sub> =0°C~70°C	-	5.0	-	%
Oscillator Voltage Swing	V <sub>OSC</sub>	4 PIN Peak to Peak	-	1.6	-	V

## ERROR AMPLIFIER SECTION

CHARACTERISTIC	SYMBOL	TEST CONDITION	MIN.	TYP.	MAX.	UNIT
Voltage Feedback Input	V <sub>FB</sub>	V <sub>O</sub> =2.5V	2.42	2.5	2.58	V
Input Bias Current	I <sub>IB</sub>	V <sub>FB</sub> =5.0V	-	-0.1	-2.0	μA
Open-Loop Voltage Gain	A <sub>VOL</sub>	V <sub>O</sub> =2.0V~4.0V	65	90	-	dB
Unity Gain Bandwidth	BW	T <sub>a</sub> =25°C	0.7	1.0	-	MHz
Power Supply Rejection Ratio	PSRR	V <sub>CC</sub> =12V~25V	60	70	-	dB
Output Sink Current	I <sub>sink</sub>	V <sub>O</sub> =1.1V, V <sub>FB</sub> =2.7V	2.0	12	-	mA
Output Source Current	I <sub>source</sub>	V <sub>O</sub> =5.0V, V <sub>FB</sub> =2.3V	-0.5	-1.0	-	
V <sub>out</sub> High	V <sub>OH</sub>	R <sub>L</sub> =15k to GND, V <sub>FB</sub> =2.3V	5.0	6.2	-	V
V <sub>out</sub> Low	V <sub>OL</sub>	R <sub>L</sub> =15k to Ref, V <sub>FB</sub> =2.7V	-	0.8	1.1	

## CURRENT SENSE SECTION

CHARACTERISTIC	SYMBOL	TEST CONDITION	MIN.	TYP.	MAX.	UNIT
Current Sense Input Voltage Gain	A <sub>v</sub>	V <sub>FB</sub> =0, V <sub>IN</sub> =0~0.8V A <sub>v</sub> = $\frac{\Delta V \text{ output Compensation}}{\Delta V \text{ Current Sense Input}}$	2.85	3.0	3.15	V/V
Maximum Current Sense Input Threshold	V <sub>th</sub>	V <sub>FB</sub> =0	0.9	1.0	1.1	V
Power Supply Rejection Ratio	PSRR	V <sub>CC</sub> =12V~25V, V <sub>FB</sub> =0	-	70	-	dB
Input Bias Current	I <sub>IB</sub>	-	-	-2.0	-10	μA
Propagation Delay	t <sub>PLH(IN/OUT)</sub>	Current Sense Input to Output	-	150	300	nS

# KIA3842P/F

## OUTPUT SECTION

CHARACTERISTIC	SYMBOL	TEST CONDITION	MIN.	TYP.	MAX.	UNIT
Low State Output Voltage	$V_{OL}$	$I_{sink}=20mA$	-	0.1	0.4	V
		$I_{sink}=200mA$	-	1.6	2.2	
High State Output Voltage	$V_{OH}$	$I_{source}=20mA$	13	13.5	-	V
		$I_{source}=200mA$	12	13.4	-	
Rise Time	$t_r$	$C_L=1.0nF, V_{FB}=0$	-	50	150	nS
Fall Time	$t_f$	$C_L=1.0nF, V_{FB}=0$	-	50	150	nS

## UNDER VOLTAGE LOCKOUT SECTION

CHARACTERISTIC	SYMBOL	TEST CONDITION	MIN.	TYP.	MAX.	UNIT
Start-up Threshold Voltage	$V_{TH}$		14.5	16	17.5	V
Minimum Operating Voltage	$V_{CC(min.)}$	After Turn ON	8.5	10	11.5	V

## PWM SECTION

CHARACTERISTIC	SYMBOL	TEST CONDITION	MIN.	TYP.	MAX.	UNIT
Duty Cycle Max.	$DC_{max.}$		94	96	-	%
Duty Cycle Min.	$DC_{min.}$		-	-	0	%

## TOTAL DEVICE

CHARACTERISTIC	SYMBOL	TEST CONDITION	MIN.	TYP.	MAX.	UNIT
Power Supply Current	$I_{CC}$	$V_{CC}=14V$	-	0.5	1.0	mA
		$V_{CC}=15V, \text{ after turn ON}$	-	12	17	
Power Supply Zener Voltage	$V_Z$	$I_{CC}=25mA$	30	36	-	V

# KIA3842P/F

## TEST CIRCUIT

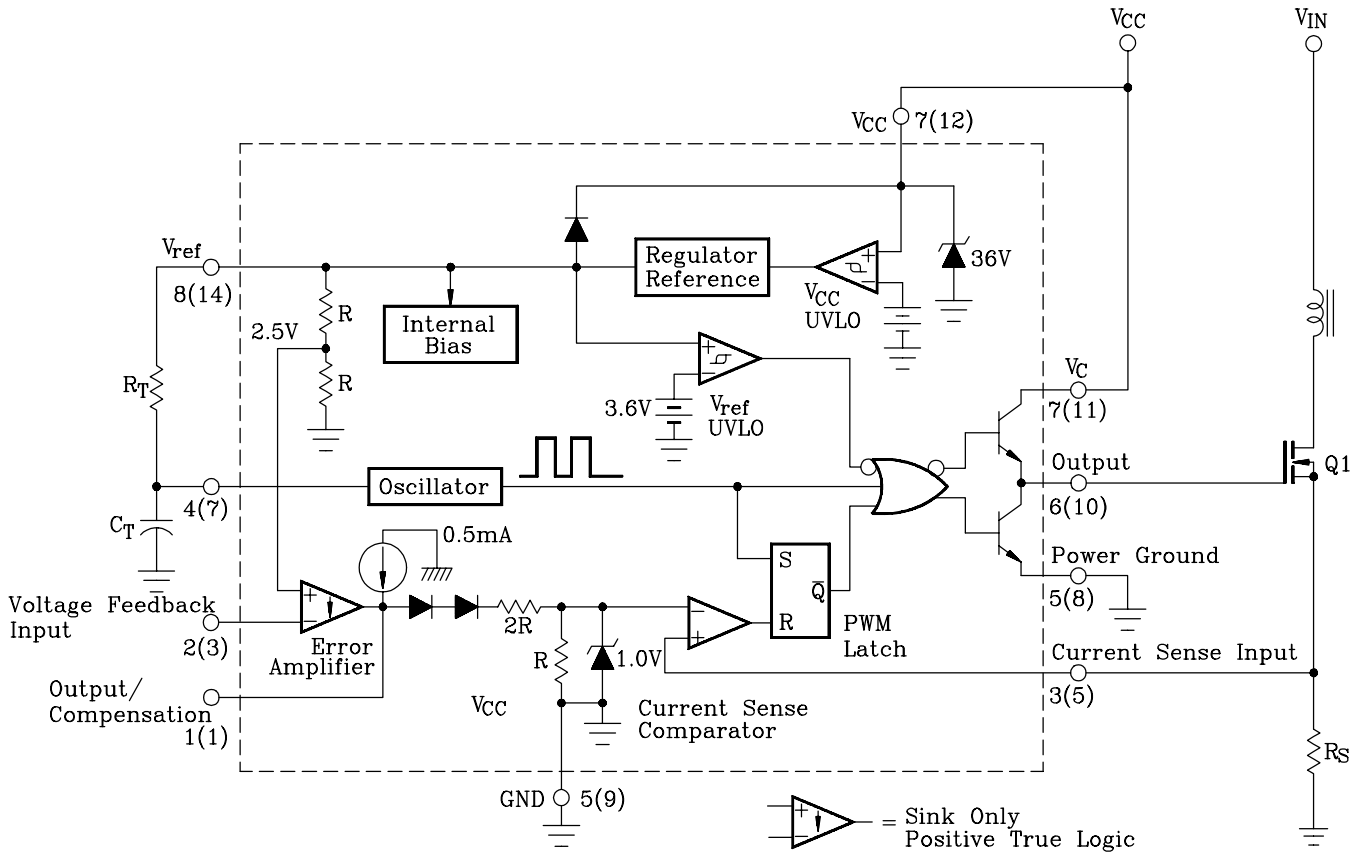

Pin numbers adjacent to terminals are for the DIP-8 package.  
Pin numbers in parenthesis are for the FLP-14 package.

# KIA3842P/F

## PIN FUNCTION DESCRIPTION

PIN NO.		FUNCTION	DESCRIPTION
8-PIN	14-PIN		
1	1	Compensation	This pin is the Error Amplifier output and is made available for loop compensation.
2	3	Voltage Feedback	This is the inverting input of the Error amplifier. It is normally connected to the switching power supply output through a resistor divider.
3	5	Current Sense	A voltage proportional to inductor current is connected to this input. The PWM uses this information to terminate the output switch conduction.
4	7	$R_T/C_T$	The Oscillator frequency and maximum Output duty Cycle are programmed by connecting resistor $R_T$ to $V_{ref}$ and capacitor $C_T$ to ground. Operation to 500kHz is possible.
5	-	GND	This pin is the combined control circuitry and power ground (8-pin package only).
6	10	Output	This output directly drives the gate of a power MOSFET. Peak currents up to 1.0A are sourced and sunk by this pin.
7	12	$V_{CC}$	This pin is the positive supply of the control IC.
8	14	$V_{ref}$	This is the reference output. It provides charging current for capacitor $C_T$ through resistor $R_T$ .
-	8	Power Ground	This pin is a separate power ground return (14pin package only) that is connected back to the power source. It is used to reduce the effects of switching transient noise on the control circuitry.
-	11	$V_C$	The output high state( $V_{OH}$ ) is set by the voltage applied to this pin (14pin package only). With a separate power source connection, It can reduce the effects of switching transient noise on the control circuitry.
-	9	GND	This pin is the control circuitry ground return (14pin package only) and is connected back to the power source ground.
-	2, 4, 6, 13	NC	No connection(14pin package only). These pins are not internally connected.

# KIA3842P/F

